

# E6C3-C

## Durable and Easy to Use

- Sealed bearings with IP65 oil resistance.
- Superior shaft loading performance.  
Radial: 80 N, Thrust: 50 N



 Be sure to read *Safety Precautions* on page 4.

## Ordering Information

**Encoders** [Refer to *Dimensions* on page 4.]

Power supply voltage	Output configuration	Resolution (pulses/rotation)	Connection method	Model
12 to 24 VDC	Complementary output	100, 200,	Pre-wired (1 m) (See note.)	<b>E6C3-CWZ5GH (resolution) 1M</b> Example: E6C3-CWZ5GH 100P/R 1M
		300, 360, 500		
		600, 720, 800		
		1,000, 1,024, 1,200		
		1,500, 1,800, 2,000		
		2,048, 2,500, 3,600		
5 to 12 VDC	Voltage output	100, 200		<b>E6C3-CWZ3EH (resolution) 1M</b> Example: E6C3-CWZ3EH 100P/R 1M
		300, 360, 500		
		600, 720, 800		
		1,000, 1,024, 1,200		
		1,500, 1,800, 2,000		
		2,048, 2,500, 3,600		
5 to 12 VDC	Line-driver output	100, 200,	<b>E6C3-CWZ3XH (resolution) 1M</b> Example: E6C3-CWZ3XH 100P/R 1M	
		300, 360, 500		
		600, 720, 800		
		1,000, 1,024, 1,200		
		1,500, 1,800, 2,000		
		2,048, 2,500, 3,600		

Note: Models with 2-m cable are also available. When ordering, specify the cable length at the end of the model number (example: E6C3-CWZ5GH 300P/R 2M).

## Accessories (Order Separately) [Refer to *Dimensions on Rotary Encoder Accessories.*]

Name	Model	Remarks
Couplings	E69-C08B	---
	E69-C68B	Different end diameter (6 to 8 mm)
Flanges	E69-FCA03	---
	E69-FCA04	E69-2 Servo Mounting Bracket provided.
Servo Mounting Bracket	E69-2	Provided with E69-FCA04 Flange.

Refer to *Accessories* for details.

## Ratings and Specifications

Item	Model	E6C3-CWZ5GH	E6C3-CWZ3EH	E6C3-CWZ3XH
Power supply voltage		12 VDC -10% to 24 VDC +15%, ripple (p-p): 5% max.	5 VDC -5% to 12 VDC +10%, ripple (p-p): 5% max.	
Current consumption*1		100 mA max.		
Resolution (pulses/rotation)		100, 200, 300, 360, 500, 600, 720, 800, 1,000, 1,024, 1,200, 1,500, 1,800, 2,000, 2,048, 2,500, 3,600		
Output phases		Phases A, B, and Z*5		Phases A, $\bar{A}$ , B, $\bar{B}$ , Z, and $\bar{Z}$
Output configuration		Complementary outputs*2	Voltage output (NPN output)	Line driver output*3
Output capacity		Output voltage: $V_H = V_{CC} = 3 \text{ V min.}$ ( $I_O = 30 \text{ mA}$ ) $V_L = 2 \text{ V max.}$ ( $I_O = -30 \text{ mA}$ ) Output current: $\pm 30 \text{ mA}$	Output resistance: 2 k $\Omega$ Output current: 35 mA max. Residual voltage: 0.7 V max.	AM26LS31 equivalent Output current: High level: $I_O = -10 \text{ mA}$ Low level: $I_S = 10 \text{ mA}$ Output voltage: $V_O = 2.5 \text{ V min.}$ $V_S = 0.5 \text{ V max.}$
Maximum response frequency*4		125 kHz (65 kHz when using phase Z reset)		
Phase difference between outputs		90°±45° between A and B (1/4 T ± 1/8 T)		
Rise and fall times of output		1 $\mu\text{s}$ max. (Cable length: 2 m, Output current: 30 mA)	1 $\mu\text{s}$ max. (Cable length: 2 m, Output current: 35 mA)	1 $\mu\text{s}$ max. (Cable length: 2 m, $I_O = -10 \text{ mA}$ , $I_S = 10 \text{ mA}$ )
Starting torque		10 mN·m max. at room temperature, 30 mN·m max. at low temperature		
Moment of inertia		2.0 × 10 <sup>-6</sup> kg·m <sup>2</sup> max.; 1.9 × 10 <sup>-6</sup> kg·m <sup>2</sup> max. at 500 P/R max.		
Shaft loading	Radial	80 N		
	Thrust	50 N		
Maximum permissible speed		5,000 r/min		
Protection circuits		Power supply reverse polarity protection, Output load short-circuit protection		---
Ambient temperature range		Operating: -10 to 70°C (with no icing), Storage: -25 to 85°C (with no icing)		
Ambient humidity range		Operating/Storage: 35% to 85% (with no condensation)		
Insulation resistance		20 M $\Omega$ min. (at 500 VDC) between current-carrying parts and case		
Dielectric strength		500 VAC, 50/60 Hz for 1 min between current-carrying parts and case		
Vibration resistance		Destruction: 10 to 500 Hz, 150 m/s <sup>2</sup> or 2-mm double amplitude for 11 min 3 times each in X, Y, and Z directions		
Shock resistance		Destruction: 1,000 m/s <sup>2</sup> 3 times each in X, Y, and Z directions		
Degree of protection		IEC 60529 IP65, in-house standards: oilproof		
Connection method		Pre-wired Models (Standard cable length: 1 m)		
Material		Case: Aluminum, Main unit: Aluminum, Shaft: SUS303		
Weight (packed state)		Approx. 300 g		
Accessories		Instruction manual		

\*1. An inrush current of approximately 9 A will flow for approximately 0.1 ms when the power is turned ON.

\*2. Complementary Output

The complementary output has two output transistors (NPN and PNP) as shown below. These two output transistors alternately turn ON and OFF depending on the high or low output signal. When using them, pull up to the positive power supply voltage level or pull down to 0 V. The complementary output allows flow-in or flow-out of the output current and thus the rising and falling speeds of signals are fast. This allows a long cable distance. They can be connected to open-collector input devices (NPN, PNP).

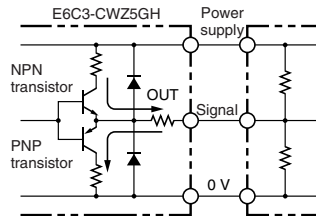

\*3. The line driver output is a data transmission circuit compatible with RS-422A and long-distance transmission is possible with a twisted-pair cable. (AM26LS31 equivalent)

\*4. The maximum electrical response speed is determined by the resolution and maximum response frequency as follows:

$$\text{Maximum electrical response speed (rpm)} = \frac{\text{Maximum response frequency}}{\text{Resolution}} \times 60$$

This means that the Rotary Encoder will not operate electrically if its speed exceeds the maximum electrical response speed.

\*5. The phase Z signal is output when cut face D on the shaft and the cable connection direction are as shown in the following diagram (output position range: ±15°).

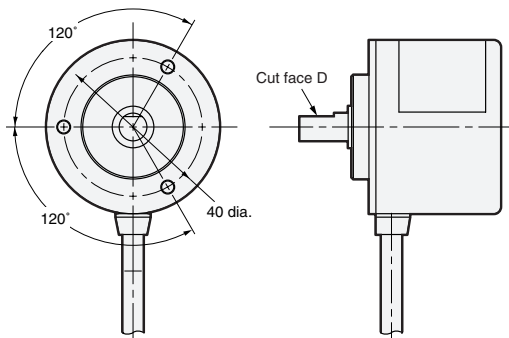

## I/O Circuit Diagrams

Model/Output Circuits	Output mode	Connection																		
<p><b>E6C3-CWZ5GH</b></p> <p>12 VDC -10% to 24 VDC +15%</p> <p>Output signal (Black: phase A, White: phase B, Orange: phase Z)</p> <p>0 V</p> <p>GND</p>	<p><b>E6C3-CWZ3EH Voltage Output Model</b> <b>E6C3-CWZ5GH Complementary Output Model</b></p> <p>Direction of rotation: CW (as viewed from end of shaft)      Direction of rotation: CCW (as viewed from end of shaft)</p> <p>Note: Phase A is <math>1/4 T \pm 1/8 T</math> faster than phase B.      Note: Phase A is <math>1/4 T \pm 1/8 T</math> slower than phase B.</p>	<table border="1"> <thead> <tr> <th>Color</th> <th>Terminal</th> </tr> </thead> <tbody> <tr> <td>Brown</td> <td>Power supply (+Vcc)</td> </tr> <tr> <td>Black</td> <td>Output phase A</td> </tr> <tr> <td>White</td> <td>Output phase B</td> </tr> <tr> <td>Orange</td> <td>Output phase Z</td> </tr> <tr> <td>Blue</td> <td>0 V (common)</td> </tr> </tbody> </table>	Color	Terminal	Brown	Power supply (+Vcc)	Black	Output phase A	White	Output phase B	Orange	Output phase Z	Blue	0 V (common)						
Color	Terminal																			
Brown	Power supply (+Vcc)																			
Black	Output phase A																			
White	Output phase B																			
Orange	Output phase Z																			
Blue	0 V (common)																			
<p><b>E6C3-CWZ3EH</b></p> <p>5 VDC -5% to 12 VDC +10%</p> <p>Output signal (Black: phase A, White: phase B, Orange: phase Z)</p> <p>0 V</p> <p>GND</p>	<p><b>E6C3-CWZ3XH Line Driver Output Model</b></p> <p>Direction of rotation: CW (as viewed from end of shaft)      Direction of rotation: CCW (as viewed from end of shaft)</p> <p>Note: Phase A is <math>1/4 T \pm 1/8 T</math> faster than phase B.      Note: Phase A is <math>1/4 T \pm 1/8 T</math> slower than phase B.</p>	<table border="1"> <thead> <tr> <th>Color</th> <th>Terminal</th> </tr> </thead> <tbody> <tr> <td>Brown</td> <td>Power supply (+Vcc)</td> </tr> <tr> <td>Black</td> <td>Output phase A</td> </tr> <tr> <td>White</td> <td>Output phase B</td> </tr> <tr> <td>Orange</td> <td>Output phase Z</td> </tr> <tr> <td>Black/red stripes</td> <td>Output phase <math>\bar{A}</math></td> </tr> <tr> <td>White/red stripes</td> <td>Output phase <math>\bar{B}</math></td> </tr> <tr> <td>Orange/red stripes</td> <td>Output phase <math>\bar{Z}</math></td> </tr> <tr> <td>Blue</td> <td>0 V (common)</td> </tr> </tbody> </table> <p>Note: Receiver: AM26LS32 equivalent</p>	Color	Terminal	Brown	Power supply (+Vcc)	Black	Output phase A	White	Output phase B	Orange	Output phase Z	Black/red stripes	Output phase $\bar{A}$	White/red stripes	Output phase $\bar{B}$	Orange/red stripes	Output phase $\bar{Z}$	Blue	0 V (common)
Color	Terminal																			
Brown	Power supply (+Vcc)																			
Black	Output phase A																			
White	Output phase B																			
Orange	Output phase Z																			
Black/red stripes	Output phase $\bar{A}$																			
White/red stripes	Output phase $\bar{B}$																			
Orange/red stripes	Output phase $\bar{Z}$																			
Blue	0 V (common)																			
<p><b>E6C3-CWZ3XH</b></p> <p>5 VDC -5% to 12 VDC +10%</p> <p>Non-reversed output (Black: phase A, White: phase B, Orange: phase Z)</p> <p>Reversed output (Black/red: phase <math>\bar{A}</math>, White/red: phase <math>\bar{B}</math>, orange/red: phase <math>\bar{Z}</math>)</p> <p>0 V</p> <p>GND</p>																				

- Note: 1. The shielded cable outer core (shield) is not connected to the inner area or to the case.  
 2. The phase A, phase B, and phase Z circuits are all identical.  
 3. Normally, connect GND to 0 V or to an external ground.

## Safety Precautions

Refer to *Warranty and Limitations of Liability*.

**⚠ WARNING**

This product is not designed or rated for ensuring safety of persons either directly or indirectly. Do not use it for such purposes.



**Precautions for Correct Use**

Do not use the Encoder under ambient conditions that exceed the ratings.

● **Wiring**

**Connections**

Cable Extension Characteristics

- When the cable length is extended, the output waveform startup time is lengthened and it affects the phase difference characteristics of phases A and B. Conditions will change according to frequency, noise, and other factors. As a guideline, use a cable length of 10 m\* or less. If the cable must be more than 10 m, use a Model with a Line-driver Output or Complementary Output.

(max. length for line-driver output: 100 m,  
max. length for complementary output: 30 m)

- \* Recommended Cable  
Conductor cross section: 0.2 mm<sup>2</sup>  
Spiral shield  
Conductor resistance: 92 Ω/km max. (20°C)  
Insulation resistance: 5 Ω/km min. (20°C)

- The output waveform startup time changes not only according to the length of the cable, but also according to the load resistance and the cable type.
- Extending the cable length not only changes the startup time, but also increases the output residual voltage.

● **Connection**

Spurious pulses may be generated when power is turned ON and OFF. Wait at least 0.1 s after turning ON the power to the Encoder before using the connected device, and stop using the connected device at least 0.1 s before turning OFF the power to the Encoder. Also, turn ON the power to the load only after turning ON the power to the Encoder.

(Unit: mm)

## Dimensions

Tolerance class IT16 applies to dimensions in this datasheet unless otherwise specified.

### Encoder

E6C3-CWZ□□H

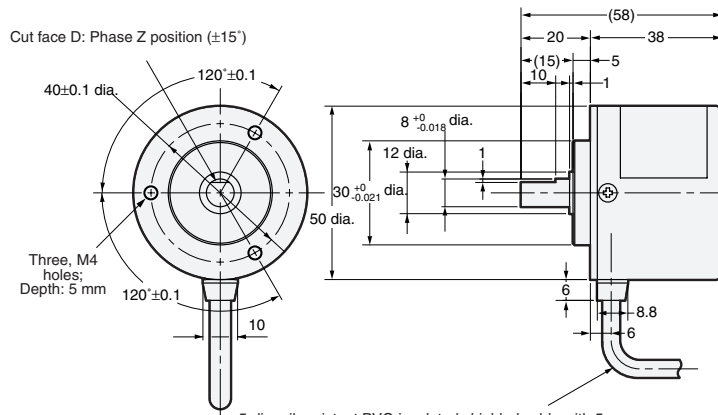
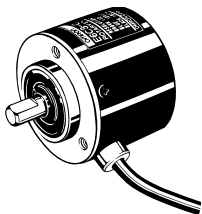

The E69-C08B Coupling is sold separately.

## Accessories (Order Separately)

**Couplings**

- E69-C08B
- E69-C68B

**Flanges**

- E69-FCA03
- E69-FCA04

**Servo Mounting Bracket**

E69-2

Refer to *Accessories* for details.

## Read and Understand This Catalog

Please read and understand this catalog before purchasing the products. Please consult your OMRON representative if you have any questions or comments.

## Warranty and Limitations of Liability

### WARRANTY

OMRON's exclusive warranty is that the products are free from defects in materials and workmanship for a period of one year (or other period if specified) from date of sale by OMRON.

OMRON MAKES NO WARRANTY OR REPRESENTATION, EXPRESS OR IMPLIED, REGARDING NON-INFRINGEMENT, MERCHANTABILITY, OR FITNESS FOR PARTICULAR PURPOSE OF THE PRODUCTS. ANY BUYER OR USER ACKNOWLEDGES THAT THE BUYER OR USER ALONE HAS DETERMINED THAT THE PRODUCTS WILL SUITABLY MEET THE REQUIREMENTS OF THEIR INTENDED USE. OMRON DISCLAIMS ALL OTHER WARRANTIES, EXPRESS OR IMPLIED.

### LIMITATIONS OF LIABILITY

OMRON SHALL NOT BE RESPONSIBLE FOR SPECIAL, INDIRECT, OR CONSEQUENTIAL DAMAGES, LOSS OF PROFITS OR COMMERCIAL LOSS IN ANY WAY CONNECTED WITH THE PRODUCTS, WHETHER SUCH CLAIM IS BASED ON CONTRACT, WARRANTY, NEGLIGENCE, OR STRICT LIABILITY.

In no event shall the responsibility of OMRON for any act exceed the individual price of the product on which liability is asserted.

IN NO EVENT SHALL OMRON BE RESPONSIBLE FOR WARRANTY, REPAIR, OR OTHER CLAIMS REGARDING THE PRODUCTS UNLESS OMRON'S ANALYSIS CONFIRMS THAT THE PRODUCTS WERE PROPERLY HANDLED, STORED, INSTALLED, AND MAINTAINED AND NOT SUBJECT TO CONTAMINATION, ABUSE, MISUSE, OR INAPPROPRIATE MODIFICATION OR REPAIR.

## Application Considerations

### SUITABILITY FOR USE

OMRON shall not be responsible for conformity with any standards, codes, or regulations that apply to the combination of products in the customer's application or use of the products.

At the customer's request, OMRON will provide applicable third party certification documents identifying ratings and limitations of use that apply to the products. This information by itself is not sufficient for a complete determination of the suitability of the products in combination with the end product, machine, system, or other application or use.

The following are some examples of applications for which particular attention must be given. This is not intended to be an exhaustive list of all possible uses of the products, nor is it intended to imply that the uses listed may be suitable for the products:

- Outdoor use, uses involving potential chemical contamination or electrical interference, or conditions or uses not described in this catalog.
- Nuclear energy control systems, combustion systems, railroad systems, aviation systems, medical equipment, amusement machines, vehicles, safety equipment, and installations subject to separate industry or government regulations.
- Systems, machines, and equipment that could present a risk to life or property.

Please know and observe all prohibitions of use applicable to the products.

NEVER USE THE PRODUCTS FOR AN APPLICATION INVOLVING SERIOUS RISK TO LIFE OR PROPERTY WITHOUT ENSURING THAT THE SYSTEM AS A WHOLE HAS BEEN DESIGNED TO ADDRESS THE RISKS, AND THAT THE OMRON PRODUCTS ARE PROPERLY RATED AND INSTALLED FOR THE INTENDED USE WITHIN THE OVERALL EQUIPMENT OR SYSTEM.

### PROGRAMMABLE PRODUCTS

OMRON shall not be responsible for the user's programming of a programmable product, or any consequence thereof.

## Disclaimers

### CHANGE IN SPECIFICATIONS

Product specifications and accessories may be changed at any time based on improvements and other reasons.

It is our practice to change model numbers when published ratings or features are changed, or when significant construction changes are made. However, some specifications of the products may be changed without any notice. When in doubt, special model numbers may be assigned to fix or establish key specifications for your application on your request. Please consult with your OMRON representative at any time to confirm actual specifications of purchased products.

### DIMENSIONS AND WEIGHTS

Dimensions and weights are nominal and are not to be used for manufacturing purposes, even when tolerances are shown.

### PERFORMANCE DATA

Performance data given in this catalog is provided as a guide for the user in determining suitability and does not constitute a warranty. It may represent the result of OMRON's test conditions, and the users must correlate it to actual application requirements. Actual performance is subject to the OMRON Warranty and Limitations of Liability.

### ERRORS AND OMISSIONS

The information in this document has been carefully checked and is believed to be accurate; however, no responsibility is assumed for clerical, typographical, or proofreading errors, or omissions.

2009.2

In the interest of product improvement, specifications are subject to change without notice.

**OMRON Corporation**  
Industrial Automation Company

<http://www.ia.omron.com/>

(c)Copyright OMRON Corporation 2009 All Right Reserved.